

First edition  
2012-12-15

Corrected version  
2012-12-15

---

---

**Information technology — Automatic  
identification and data capture  
techniques — Real time locating systems  
(RTLS) device conformance test  
methods —**

Part 5:

**Test methods for chirp spread spectrum  
(CSS) at 2,4 GHz air interface**

*Technologies de l'information — Techniques d'identification  
automatique et de capture de données — Systèmes de localisation en  
temps réel (RTLS) méthodologie des tests de conformité —*

*Partie 5: Méthodologie de test de l'interface d'air à 2,4 GHz avec  
étalement de spectre par compression d'impulsions (CSS)*

---

---

Reference number  
ISO/IEC 24769-5:2012(E)





**COPYRIGHT PROTECTED DOCUMENT**

© ISO/IEC 2012

All rights reserved. Unless otherwise specified, no part of this publication may be reproduced or utilized in any form or by any means, electronic or mechanical, including photocopying and microfilm, without permission in writing from either ISO at the address below or ISO's member body in the country of the requester.

ISO copyright office  
Case postale 56 • CH-1211 Geneva 20  
Tel. + 41 22 749 01 11  
Fax + 41 22 749 09 47  
E-mail [copyright@iso.org](mailto:copyright@iso.org)  
Web [www.iso.org](http://www.iso.org)

Published in Switzerland

# Contents

Page

Foreword .....	iv
Introduction.....	v
1 Scope .....	1
2 Normative references .....	1
3 Terms and definitions .....	2
4 Symbols and abbreviated terms .....	2
5 Conformance tests for ISO/IEC 24730-5.....	3
5.1 General .....	3
5.2 Overall Test conditions.....	3
5.2.1 Test environment.....	3
5.2.2 Default tolerance .....	3
5.3 Transmitter and Receiver setup.....	3
5.3.1 Transmitting setup .....	3
5.3.2 Receiving setup .....	4
5.4 RF transmission tests .....	5
5.4.1 Test setup.....	5
5.4.2 2-ary orthogonal CSS modulation at 1 Mbits/s transmission test .....	5
5.4.3 2-ary orthogonal CSS modulation at 250 Kbits/s transmission test.....	7
5.4.4 DQPSK CSS modulation at 1 Mbits/s transmission test .....	8
5.4.5 DQPSK CSS modulation at 250 Kbits/s transmission test.....	10
5.5 RF reception tests .....	11
5.5.1 Test setup.....	11
5.5.2 2-ary orthogonal CSS modulation at 1 Mbits/s reception test.....	12
5.5.3 2-ary orthogonal CSS modulation at 250 Kbits/s reception test .....	14
5.5.4 DQPSK CSS modulation at 1 Mbits/s reception test .....	16
5.5.5 DQPSK CSS modulation at 250 Kbits/s reception test.....	17
5.6 Application layer conformance tests .....	19
5.6.1 Test setup.....	19
5.6.2 Set and get configuration vector command .....	20
5.6.3 Set, add and get ranging peer.....	21
5.6.4 Switch state command test .....	22
5.6.5 Ranging packet exchange .....	24
5.6.6 Ranging report.....	27
Annex A (normative) Technical requirements of the testing equipment.....	29
Bibliography.....	30

## Foreword

ISO (the International Organization for Standardization) and IEC (the International Electrotechnical Commission) form the specialized system for worldwide standardization. National bodies that are members of ISO or IEC participate in the development of International Standards through technical committees established by the respective organization to deal with particular fields of technical activity. ISO and IEC technical committees collaborate in fields of mutual interest. Other international organizations, governmental and non-governmental, in liaison with ISO and IEC, also take part in the work. In the field of information technology, ISO and IEC have established a joint technical committee, ISO/IEC JTC 1.

International Standards are drafted in accordance with the rules given in the ISO/IEC Directives, Part 2.

The main task of the joint technical committee is to prepare International Standards. Draft International Standards adopted by the joint technical committee are circulated to national bodies for voting. Publication as an International Standard requires approval by at least 75 % of the national bodies casting a vote.

Attention is drawn to the possibility that some of the elements of this document may be the subject of patent rights. ISO and IEC shall not be held responsible for identifying any or all such patent rights.

ISO/IEC 24769-5 was prepared by Joint Technical Committee ISO/IEC JTC 1, *Information technology*, Subcommittee SC 31, *Automatic identification and data capture techniques*.

This corrected version of ISO/IEC 24769-5:2012 incorporates the following corrections:

— All references to ISO/IEC 24703-5 have been changed to ISO/IEC 24730-5.

ISO/IEC 24769 consists of the following parts, under the general title *Information technology, Automatic identification and data capture techniques — Real time locating systems (RTLS) device conformance test methods*:

— *Part 2: Test methods for air interface communication at 2,4 GHz*

— *Part 5: Test methods for chirp spread spectrum (CSS) at 2,4 GHz air interface*

## Introduction

ISO/IEC 24730 defines air interface protocols and an Application Program Interface (API) for Real Time Locating Systems (RTLS).

ISO/IEC 24730-5 defines an air interface which utilizes Chirp Spread Spectrum (CSS) at frequencies from 2.4-2.483 GHz. Chirp pulses, which are pulses with a fast increasing or decreasing instantaneous frequency, have originally used for radar applications. Lately, chirp pulses have been also used for communication applications.

ISO/IEC 24730-5 includes ranging and bidirectional communication between tags and infrastructures. Bidirectional communication enables the infrastructure to control the behaviour of tags.

The purpose of ISO/IEC TR 24769-5 is to provide tests conditions and methods for conformance to ISO/IEC 24730-5.

ISO/IEC TR 24769-5 contains all measurements required to be made on a product in order to establish whether it conforms to ISO/IEC 24730-5.



# Information technology — Automatic identification and data capture techniques — Real time locating systems (RTLS) device conformance test methods —

## Part 5: Test methods for chirp spread spectrum (CSS) at 2,4 GHz air interface

### 1 Scope

This part of ISO/IEC 24769 defines the test methods for determining the conformance of real time locating systems (RTLS) tags and readers with the specifications given in the corresponding parts of ISO/IEC 24730-5.

This part of ISO/IEC 24769 does not include the testing of conformity with regulatory requirements.

The test methods require only that the mandatory functions, and any optional functions which are implemented, be verified

The conformance parameters described in this part of ISO/IEC 24769 include the radio frequency air interface and packet exchange required to perform the locating of the RTLS tag. It includes the mandatory 2-ary orthogonal chirp spread spectrum (CSS) modulation and the optional differential quadrature phase shift keying (DQPSK) CSS. This part of ISO/IEC 24769 also includes the ranging packet exchanges, the commands and the reports defined in ISO/IEC 24730-5.

Unless otherwise specified, the tests in this part of ISO/IEC 24769 shall be applied exclusively to RTLS tags and readers defined in ISO/IEC 24730-5.

### 2 Normative references

The following referenced documents are indispensable for the application of this document. For dated references, only the edition cited applies. For undated references, the latest edition of the referenced document (including any amendments) applies.

ISO/IEC 19762-1: *Information technology — Automatic identification and data capture (AIDC) techniques — Harmonized vocabulary — Part 1: General terms relating to AIDC*

ISO/IEC 19762-3: *Information technology — Automatic identification and data capture (AIDC) techniques — Harmonized vocabulary — Part 3: Radio-Frequency Identification (RFID)*

ISO/IEC 19762-4: *Information technology — Automatic identification and data capture (AIDC) techniques — Harmonized vocabulary — Part 4: General terms relating to radio communications*

ISO/IEC 19762-5: *Information technology — Automatic identification and data capture (AIDC) techniques — Harmonized vocabulary — Part 5: Locating systems*

ISO/IEC 24730-5: *Information technology — Real Time Locating Systems (RTLS) — Part 5: Chirp Spread Spectrum (CSS) at 2.4 GHz air interface*

### 3 Terms and definitions

For the purposes of this document, the terms and definitions given in ISO/IEC 19762-1, ISO/IEC 19762-3, ISO/IEC 19762-4, ISO/IEC 19762-5 and the following apply.

- 3.1**  
**Chirp Spread Spectrum**  
technique for spreading the bandwidth of a digital signal using linear frequency sweep signals
- 3.2**  
**Class I**  
system that operates at a radiated power up to 10 mW EIRP
- 3.3**  
**Class II**  
system that operates at a radiated power higher than 10 mW up to the maximum defined by local regulations
- 3.4**  
**Ranging**  
process of determining the distance between two RTLS transceivers through the exchange of a specific set of messages
- 3.4**  
**Ranging peer**  
RTLS transceiver to perform ranging with
- 3.5**  
**RTLS tag**  
RTLS transceiver that accepts commands from RTLS readers, sends blinks and reports to the RTLS readers

### 4 Symbols and abbreviated terms

API	Application Program Interface
AWG	Arbitrary Waveform Generator
CRC	Cyclic Redundancy Check
CSMA/CA	Carrier Sense Multiple Access / Collision Avoid
CSS	Chirp Spread Spectrum
DQPSK	Differential Quadrature Phase Shift Keying
DUT	Device Under Test
EIRP	Effective Isotropic Radiated Power
MAC	Medium Access Control
PPM	Parts Per Million
RTLS	Real Time Locating System
SG	Signal Generator



Src	Source address
T <sub>RXON</sub>	Duration of time interval during which the receiver is activated
T1R1	Application ranging packet type 1 of the ranging packet exchange type 1

## 5 Conformance tests for ISO/IEC 24730-5

### 5.1 General

This technical report specifies a series of tests to determine the conformance of RTLS tags and readers to the ISO/IEC 24730-5 air interface and packet exchanges required to be performed between tags and infrastructures in order to control and retrieve information about location and states of tags.

### 5.2 Overall Test conditions

Unless otherwise specified, these test conditions apply to all tests in this part of ISO/IEC 24769.

#### 5.2.1 Test environment

Unless otherwise specified, testing shall take place in an environment of temperature  $23^{\circ}\text{C} \pm 3^{\circ}\text{C}$  and of relative humidity 25 % to 75 %.

#### 5.2.2 Default tolerance

Unless otherwise specified, a default tolerance of  $\pm 5\%$  shall be applied to the quantity values given to specify the characteristics of the test equipment and the test method procedures.

### 5.3 Transmitter and Receiver setup

In order to perform some test cases, one or several specific setups will be required to either transmit packets or to receive and decode packets according to the ISO/IEC 24730-5 standard. These setups are described hereafter.

#### 5.3.1 Transmitting setup

The transmitting setup shall be used to validate the reception performances of the DUT and to verify the compliance of the DUT to the tag application layer by transmitting various commands.

In order to transmit data according to the specification of ISO/IEC 24730-5, the following parts are required:

- Control Application: An application which controls the signal generator in order to perform the tasks required by this part of ISO/IEC 24769.
- Arbitrary Waveform Generator: for example, a Tektronix AWG2041 or equivalent, as described in Annex A.
- Signal Generator: for example, an Agilent ESG E4438C or equivalent, as described in Annex A. If the AWG is able to deliver the proper signal at the desired frequency, the SG might not be necessary.
- Frequency Mixer: for example, a Mini-Circuits ZEM-4300+ or equivalent.

Figure 1 below shows the required transmitting setup:

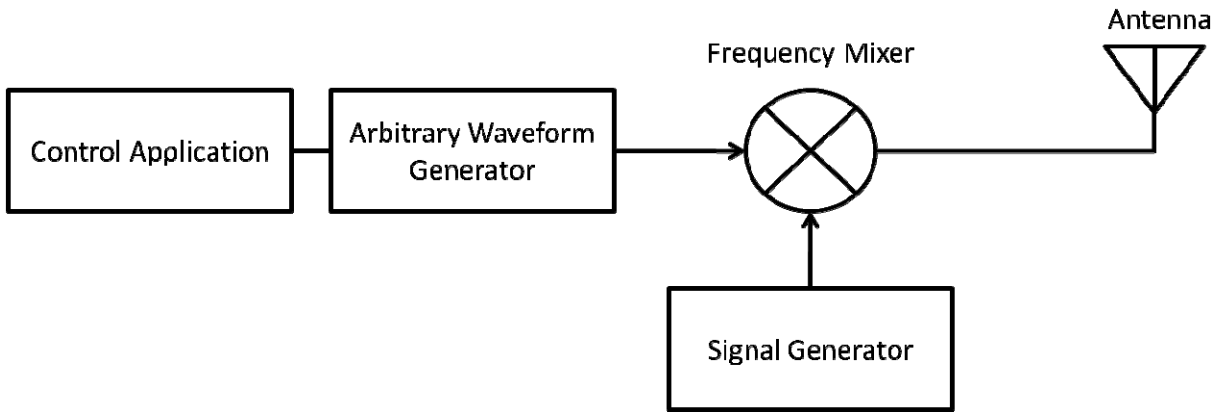

Figure 1 — Transmitting setup

### 5.3.2 Receiving setup

The receiving setup shall be used to validate the data transmitted by the DUT and to verify the compliance of the DUT to the tag application layer.

In order to receive and decode data according to the specification of ISO/IEC 24730-5, the following parts are required:

- Frequency Mixer: for example, a Mini-Circuits ZEM-4300+ or equivalent.
- Signal Generator: for example, an Agilent ESG E4438C or equivalent, as described in Annex A.
- Oscilloscope: for example, a Tektronix DPO 7104 or equivalent, as described in Annex A.
- Post processing application: An application which controls the oscilloscope in order to gather the data required to validate if the DUT is compliant with the test specification.

Figure 2 below shows the required receiving setup:

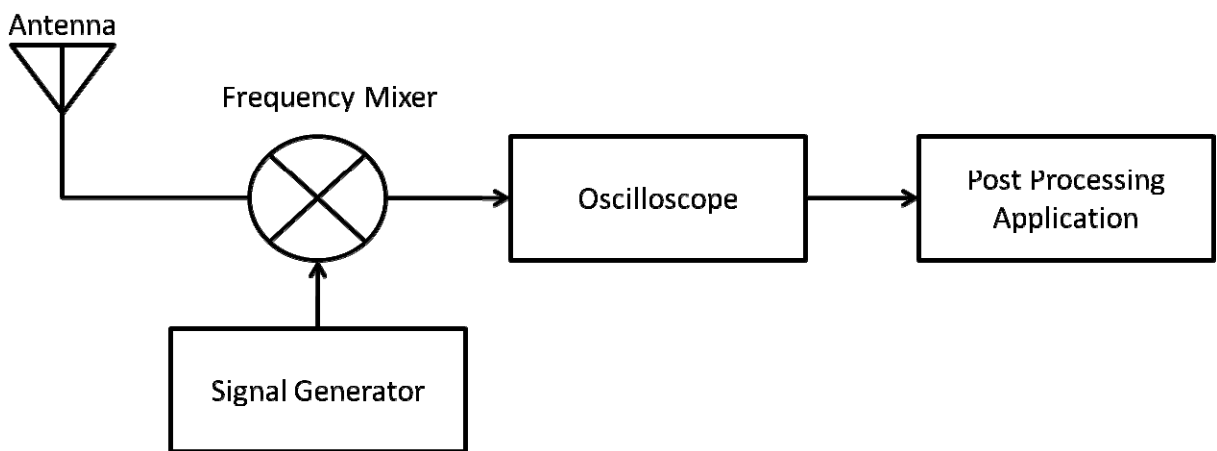

Figure 2 — Receiving setup

## 5.4 RF transmission tests

This describes the conditions and tests to validate the radio frequency transmission.

### 5.4.1 Test setup

The device under test (DUT) shall be a RTLS tag or reader. The measurement equipment shall consist of an anechoic chamber, one or several measuring antennas, a spectrum analyzer, an oscilloscope and a receiving setup.

Technical requirements of the spectrum analyzer, for example, an Agilent E4443A or equivalent, are described in Annex A.

The DUT shall be placed at a distance between 1 meter and 3 meters from the measurement antenna.

Figure 3 below shows the required test setup:

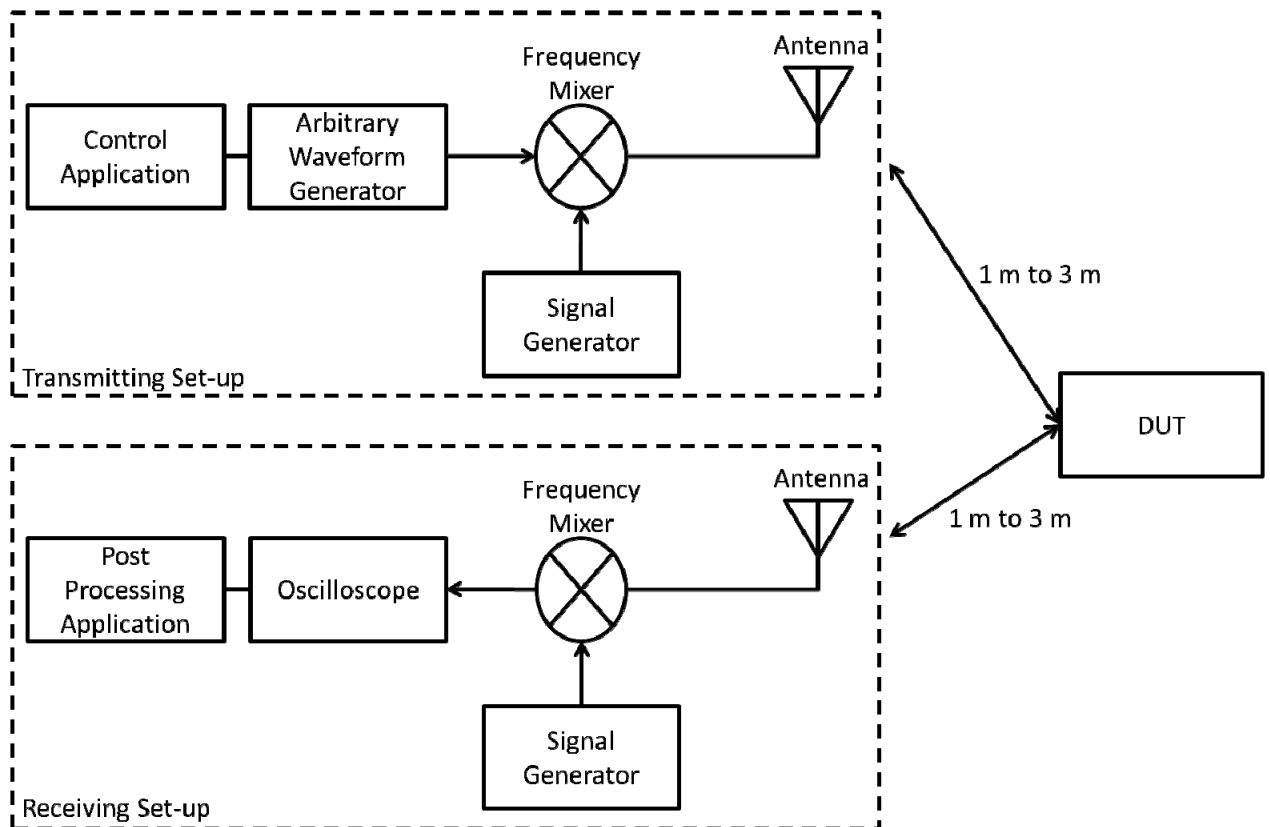

Figure 3 — RF transmission test setup

All measurement shall be done with a video and resolution bandwidth of minimum 100 KHz.

### 5.4.2 2-ary orthogonal CSS modulation at 1 Mbits/s transmission test

#### 5.4.2.1 Test objective

The objective of this test is to validate that the DUT provides the appropriate 2-ary orthogonal CSS modulation waveform and data rate defined in ISO/IEC 24730-5 and required for proper system performance.

### 5.4.2.2 Test conditions

The test setup shall be according to 5.4.1.

The DUT shall be configured with the following configuration:

- Transmit on channel 0 with a centre frequency of 2441.75 MHz (as defined in Table 2 in 7.3 of ISO/IEC 24730-5).
- Occupied channel bandwidth: 80 MHz.
- Data bit rates: 1 Mbits/s.
- Modulation: 2-ary orthogonal CSS.
- Transmit power shall be at a class 1 power between 0 dBm and +10 dBm EIRP.
- Media access: ALOHA (as defined in 8.5.4 of ISO/IEC 24730-5) which correspond to CSMA/CA off (as defined in Table 27 in 9.3.2 of ISO/IEC 24730-5).
- Transmit a blink packet (as defined in 9.4.1 of ISO/IEC 24730-5) every 1 second. As a blink packet can include user defined data, the length is not fixed but should be kept below 64 bytes in total. The total packet length shall be specified by the manufacturer of the DUT.

### 5.4.2.3 Test measurements and requirements

The person in charge of the test, or the test application, shall be able to validate the parameters described hereafter.

#### 5.4.2.3.1 Carrier frequency

The carrier frequency shall be measured with the spectrum analyzer.

The carrier frequency shall be 2441.750 MHz  $\pm$  171 KHz (70 PPM). The carrier frequency drift over the duration of the entire message shall be less than 12 KHz (5 PPM).

#### 5.4.2.3.2 Occupied channel bandwidth

The 20 dB occupied bandwidth shall be measured with the spectrum analyzer.

The 20 dB occupied bandwidth shall be below 83.5 MHz. (As specified in Figure 5 in 7.3.2 of ISO/IEC 24730-5)

#### 5.4.2.3.3 Transmit power

The power received shall be measured with the spectrum analyzer.

The transmitted power shall be calculated based on the power received at the measurement antenna. The calculated power shall be within  $\pm$  2.0 dB of the DUT specified transmitting power.

#### 5.4.2.3.4 Symbol rate

The symbol rate shall be measured with the oscilloscope. The signal can be down converted in order to increase the accuracy of the measurement.

The symbol rate of the 2-ary orthogonal CSS shall be  $10^6$  symbols per second  $\pm$  70 symbols (70 PPM).

#### 5.4.2.3.5 Message content

The message shall be decoded using the receiving setup.

The person in charge of the test or the test application shall verify that the blink message format, including preamble, start of frame delimiter, DUT ID (defined in Src of Figure 40 in 9.4.1 of ISO/IEC 24730-5) and CRC2, is in compliance with the format specified in 7.3.7, 7.3.8 and 9.4.1 of the ISO/IEC 24730-5.

#### 5.4.2.4 Test report

The test report shall contain a sketch of the test setup, the distance between the DUT and the measurement antenna, a list of the testing equipment used and all the measured data required to validate the parameters defined above.

If a test application is used, a brief narrative shall be included as an annex to the data.

The report shall also contain the uncertainties of the measurement equipment.

### 5.4.3 2-ary orthogonal CSS modulation at 250 Kbits/s transmission test

#### 5.4.3.1 Test objective

The objective of this test is to validate that the DUT provides the appropriate 2-ary orthogonal CSS modulation waveform and data rate defined in ISO/IEC 24730-5 and required for proper system performance.

#### 5.4.3.2 Test conditions

The test setup shall be according to 5.4.1.

The DUT shall be configured with the following configuration:

- Transmit on channel 2 with a centre frequency of 2412 MHz (as defined in Table 2 in 7.3 of ISO/IEC 24730-5).
- Occupied channel bandwidth: 22 MHz.
- Data bit rates: 250 Kbits/s.
- Modulation: 2-ary orthogonal CSS.
- Transmit power shall be at a class 1 power between 0 dBm and +10 dBm EIRP.
- Media access: ALOHA (as defined in 8.5.4 of ISO/IEC 24730-5) which correspond to CSMA/CA off (as defined in Table 27 in 9.3.2 of ISO/IEC 24730-5).
- Transmit a blink packet (as defined in 9.4.1 of ISO/IEC 24730-5) every 1 second. As a blink packet can include user defined data, the length is not fixed but should be kept below 64 bytes in total. The total packet length shall be specified by the manufacturer of the DUT.

#### 5.4.3.3 Test measurements and requirements

The person in charge of the test, or the test application, shall be able to validate the parameters described hereafter.

##### 5.4.3.3.1 Carrier frequency

The carrier frequency shall be measured with the spectrum analyzer.

## ISO/IEC 24769-5:2012(E)

The carrier frequency shall be 2412 MHz  $\pm$  169 KHz (70 PPM). The carrier frequency drift over the duration of the entire message shall be less than 12 KHz (5 PPM).

### 5.4.3.3.2 Occupied channel bandwidth

The 20 dB occupied bandwidth shall be measured with the spectrum analyzer.

The 20 dB occupied bandwidth shall be below 22 MHz. (As specified in Figure 6 in 7.3.2 of ISO/IEC 24730-5).

### 5.4.3.3.3 Transmit power

The power received shall be measured with the spectrum analyzer.

The transmitted power shall be calculated based on the power received at the measurement antenna. The calculated power shall be within  $\pm$  2.0 dB of the DUT specified transmitting power.

### 5.4.3.3.4 Symbol rate

The symbol rate shall be measured with the oscilloscope. The signal can be down converted in order to increase the accuracy of the measurement.

The symbol rate of the 2-ary orthogonal CSS shall be 250 000 symbols per second  $\pm$  17 symbols (70 PPM).

### 5.4.3.3.5 Message content

The message shall be decoded using a receiving setup.

The person in charge of the test or the test application shall verify that the blink message format, including preamble, start of frame delimiter, DUT ID (defined in Src of Figure 40 in 9.4.1 of ISO/IEC 24730-5) and CRC2, is in compliance with the format specified in 7.3.7, 7.3.8 and 9.4.1 of the ISO/IEC 24730-5.

### 5.4.3.4 Test report

The test report shall contain a sketch of the test setup, the distance between the DUT and the measurement antenna, a list of the testing equipment used and all the measured data required to validate the parameters defined above.

If a test application is used, a brief narrative shall be included as an annex to the data.

The report shall also contain the uncertainties of the measurement equipment.

## 5.4.4 DQPSK CSS modulation at 1 Mbits/s transmission test

As this modulation is optional in the ISO/IEC 24730-5, this applies only to devices which state its implementation.

### 5.4.4.1 Test objective

The objective of this test is to validate that the DUT provides the appropriate differential Quadrature Phase Shift Keying CSS modulation waveform and data rate defined in ISO/IEC 24730-5 and required for proper system performance.

#### 5.4.4.2 Test conditions

The test setup shall be according to 5.4.1.

The DUT shall be configured with the following configuration:

- Transmit on channel 2 with a centre frequency of 2412 MHz (as defined in Table 2 in 7.3 and Table 6 in 7.4 of ISO/IEC 24730-5).
- Occupied channel bandwidth: 22 MHz.
- Data bit rates: 1 Mbits/s.
- Modulation: DQPSK CSS.
- Transmit power shall be at a class 1 power between 0 dBm and +10 dBm EIRP.
- Media access: ALOHA (as defined in 8.5.4 of ISO/IEC 24730-5) which correspond to CSMA/CA off (as defined in Table 27 in 9.3.2 of ISO/IEC 24730-5).
- Transmit a blink packet (as defined in 9.4.1 of ISO/IEC 24730-5) every 1 second. As a blink packet can include user defined data, the length is not fixed but should be kept below 64 bytes in total. The total packet length shall be specified by the manufacturer of the DUT.

#### 5.4.4.3 Test measurements and requirements

The person in charge of the test, or the test application, shall be able to validate the parameters described hereafter.

##### 5.4.4.3.1 Carrier frequency

If the DUT is able to send a carrier, the carrier frequency shall be measured with the spectrum analyzer.

The carrier frequency shall be 2412 MHz  $\pm$  97 KHz (40 PPM). The carrier frequency drift over the duration of the entire message shall be less than 12 KHz (5 PPM).

##### 5.4.4.3.2 Occupied channel bandwidth

The occupied bandwidth shall be measured with the spectrum analyzer.

The 30 dB occupied bandwidth shall be below 22 MHz. (As specified in Figure 13 in 7.4.2 of ISO/IEC 24730-5). Additionally, the spectral power density shall be according to Figure 13 in 7.4.2 of ISO/IEC 24730-5.

##### 5.4.4.3.3 Transmit power

The power received shall be measured with the spectrum analyzer.

The transmitted power shall be calculated based on the power received at the measurement antenna. The calculated power shall be within  $\pm$  2.0 dB of the DUT specified transmitting power.

##### 5.4.4.3.4 Symbol rate

The symbol rate shall be measured with the oscilloscope. The signal can be down converted in order to increase the accuracy of the measurement.

The symbol rate of the 2-ary orthogonal CSS shall be 166 667 symbols per second  $\pm$  7 symbols (40 PPM).

### 5.4.4.3.5 Message content

The message shall be decoded using a receiving setup.

The person in charge of the test or the test application shall verify that the blink message format, including preamble, start of frame delimiter, DUT ID (defined in Src of Figure 40 in 9.4.1 of ISO/IEC 24730-5) and CRC2, is in compliance with the format specified in 7.3.7, 7.3.8 and 9.4.1 of the ISO/IEC 24730-5.

### 5.4.4.4 Test report

The test report shall contain a sketch of the test setup, the distance between the DUT and the measurement antenna, a list of the testing equipment used and all the measured data required to validate the parameters defined above.

If a test application is used, a brief narrative shall be included as an annex to the data.

The report shall also contain the uncertainties of the measurement equipment.

## 5.4.5 DQPSK CSS modulation at 250 Kbits/s transmission test

As this modulation is optional in the ISO/IEC 24730-5, this applies only to devices which state its implementation.

### 5.4.5.1 Test objective

The objective of this test is to validate that the DUT provides the appropriate differential Quadrature Phase Shift Keying CSS modulation waveform and data rate defined in ISO/IEC 24730-5 and required for proper system performance.

### 5.4.5.2 Test conditions

The test setup shall be according to 5.4.1.

The DUT shall be configured with the following configuration:

- Transmit on channel 2 with a centre frequency of 2412 MHz (as defined in Table 2 in 7.3 and Table 6 in 7.4 of ISO/IEC 24730-5).
- Occupied channel bandwidth: 22 MHz.
- Data bit rates: 250 Kbits/s.
- Modulation: DQPSK CSS.
- Transmit power shall be at a class 1 power between 0 dBm and +10 dBm EIRP.
- Media access: ALOHA (as defined in 8.5.4 of ISO/IEC 24730-5) which correspond to CSMA/CA off (as defined in Table 27 in 9.3.2 of ISO/IEC 24730-5).
- Transmit a blink packet (as defined in 9.4.1 of ISO/IEC 24730-5) every 1 second. As a blink packet can include user defined data, the length is not fixed but should be kept below 64 bytes in total. The total packet length shall be specified by the manufacturer of the DUT.

### 5.4.5.3 Test measurements and requirements

The person in charge of the test, or the test application, shall be able to validate the parameters described hereafter.



**5.4.5.3.1 Carrier frequency**

If the DUT is able to send a carrier, the carrier frequency shall be measured with the spectrum analyzer.

The carrier frequency shall be 2412 MHz  $\pm$  97 KHz (40 PPM). The carrier frequency drift over the duration of the entire message shall be less than 12 KHz (5 PPM).

**5.4.5.3.2 Occupied channel bandwidth**

The occupied bandwidth shall be measured with the spectrum analyzer.

The 30 dB occupied bandwidth shall be below 22 MHz. (As specified in Figure 13 in 7.4.2 of ISO/IEC 24730-5). Additionally, the spectral power density shall be according to Figure 13 in 7.4.2 of ISO/IEC 24730-5.

**5.4.5.3.3 Transmit power**

The power received shall be measured with the spectrum analyzer.

The transmitted power shall be calculated based on the power received at the measurement antenna. The calculated power shall be within  $\pm$  2.0 dB of the DUT specified transmitting power.

**5.4.5.3.4 Symbol rate**

The symbol rate shall be measured with the oscilloscope. The signal can be down converted in order to increase the accuracy of the measurement.

The symbol rate of the 2-ary orthogonal CSS shall be 166 667 symbols per second  $\pm$  7 symbols (40 PPM).

**5.4.5.3.5 Message content**

The message shall be decoded using a receiving setup.

The person in charge of the test or the test application shall verify that the blink message format, including preamble, start of frame delimiter, DUT ID (defined in Src of Figure 40 in 9.4.1 of ISO/IEC 24730-5) and CRC2, is in compliance with the format specified in 7.3.7, 7.3.8 and 9.4.1 of the ISO/IEC 24730-5.

**5.4.5.4 Test report**

The test report shall contain a sketch of the test setup, the distance between the DUT and the measurement antenna, a list of the testing equipment used and all the measured data required to validate the parameters defined above.

If a test application is used, a brief narrative shall be included as an annex to the data.

The report shall also contain the uncertainties of the measurement equipment.

**5.5 RF reception tests**

This describes the conditions and tests to validate the radio frequency reception.

**5.5.1 Test setup**

The measurement equipment shall consist of an anechoic chamber, a transmitting setup and a receiving setup.

The DUT shall be a RTLS tag or reader.

The DUT shall be placed at a distance between 1 meter and 3 meters from the measurement antenna.

The data will be transmitted by a transmitting setup. The person in charge of the test shall verify that the transmitting setup complies with the RF transmission test, as defined in 5.4 of this part of ISO/IEC 24769.

Figure 4 below shows the required test setup:

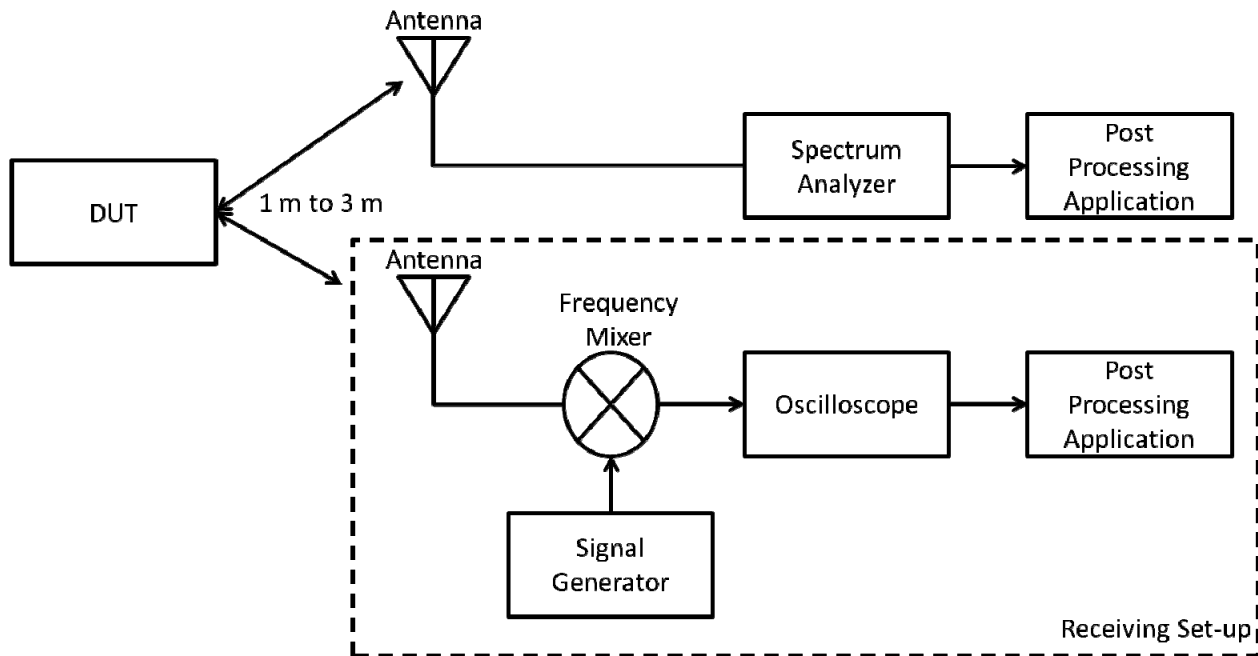

Figure 4 — RF reception test setup

### 5.5.2 2-ary orthogonal CSS modulation at 1 Mbits/s reception test

#### 5.5.2.1 Test objective

The objective of this test is to validate that the DUT provides the appropriate 2-ary orthogonal CSS modulation waveform detection required for proper system performance.

#### 5.5.2.2 Test conditions

The test setup shall be according to 5.5.1.

The DUT shall be configured with the following configuration:

- Operation on channel 0 with a centre frequency of 2441.75 MHz (as defined in Table 2 in 7.3 of ISO/IEC 24730-5).
- Occupied channel bandwidth : 80 MHz.
- Data bit rates: 1 Mbits/s.
- Modulation: 2-ary orthogonal CSS.
- Transmit power shall be at a class 1 power between 0 dBm and +10 dBm EIRP.

- Media access: ALOHA (as defined in 8.5.4 of ISO/IEC 24730-5) which correspond to CSMA/CA off (as defined in Table 27 in 9.3.2 of ISO/IEC 24730-5).

Additionally, as the operation of a tag and a reader differ, the configuration and test procedure will be different depending on if the DUT is a tag or a reader.

### 5.5.2.3 Test measurements and requirements

The person in charge of the test, or the test application, shall be able to validate the parameters described hereafter.

#### 5.5.2.3.1 Receiver input RF power levels

The transmitting setup shall be configured to provide two input signals to the DUT:

- - 80 dBm for threshold sensitivity
- - 40 dBm for dynamic range

#### 5.5.2.3.2 Detection error magnitude

Depending on if the DUT is a tag or a reader, the test procedure will differ.

##### 5.5.2.3.2.1 The device under test is a tag

The DUT shall be additionally configured with the following configuration:

- Transmit a blink packet (as defined in 9.4.1 of ISO/IEC 24730-5) every 2 seconds. As a blink packet can include user defined data, the length is not fixed but should be kept below 64 bytes in total. The total packet length shall be specified by the manufacturer of the DUT.
- Each blink shall be followed by a receiving window of duration  $T_{RXON}$  equal to 1 second as defined in 9.2.5 of ISO/IEC 24730-5.

As a tag will transmit a blink packet before entering the receiving window, the testing application controlling the transmitting setup shall not start any transmission before the reception of the blink.

The transmission of packet by the transmitting setup shall start 3 milliseconds (ms) after the reception of the blink.

During the DUT's receiving window duration, the transmitting setup shall send 200 packets with an estimated interval of 2 ms between each packet. The transmitting setup shall stop to transmit packet 10 ms before the estimated end of the receiving window of the DUT.

The packet sent to the DUT shall be an AddRangingPeers command, as defined in 9.3.5 of ISO/IEC 24730-5, with the following parameter:

- Number of peers = 0

For the 2 RF input levels (2 tests in total), the reception error shall be better than 95 % of all commands sent. Each test shall consist of a minimum of 2000 commands.

##### 5.5.2.3.2.2 The device under test is a reader

The transmitting setup shall transmit blink (as defined in 9.4.1 of ISO/IEC 24730-5) with an interval between blinks of 2 ms.

For the 2 RF input levels (2 tests in total), the reception error shall be better than 95 % of all blinks sent. Each test shall consist of a minimum of 2000 blinks.

#### **5.5.2.4 Test report**

The test report shall contain a sketch of the test setup, the distance between the DUT and the measurement antenna, a list of the testing equipment used and all the measured data required to validate the parameters defined above.

If a test application is used, a brief narrative shall be included as an annex to the data.

The report shall also contain the uncertainties of the measurement equipment.

### **5.5.3 2-ary orthogonal CSS modulation at 250 Kbits/s reception test**

#### **5.5.3.1 Test objective**

The objective of this test is to validate that the DUT provides the appropriate 2-ary orthogonal CSS modulation waveform detection required for proper system performance.

#### **5.5.3.2 Test conditions**

The test setup shall be according to 5.5.1.

The DUT shall be configured with the following configuration:

- Occupied channel bandwidth: 22 MHz
- Data bit rates: 250 kbits/s
- Modulation: 2-ary orthogonal CSS
- Transmit power shall be at a class 1 power between 0 dBm and +10 dBm EIRP
- Media access: ALOHA (as defined in 8.5.4 of ISO/IEC 24730-5) which correspond to CSMA/CA off (as defined in Table 27 in 9.3.2 of ISO/IEC 24730-5)

Additionally, as the operation of a tag and a reader differ, the configuration and test procedure will be different depending on if the DUT is a tag or a reader.

#### **5.5.3.3 Test measurements and requirements**

The person in charge of the test, or the test application, shall be able to validate the parameters described hereafter.

##### **5.5.3.3.1 Channel used**

The transmitting setup and the DUT shall be tested at the following channel, as defined in Table 2 in 7.3 of ISO/IEC 24730-5:

- Channel 2 : centre frequency of 2412 MHz
- Channel 8: centre frequency of 2442 MHz
- Channel 15: centre frequency of 2484 MHz

### 5.5.3.3.2 Receiver input RF power levels

The transmitting setup shall be configured to provide two input signals to the DUT:

- - 80 dBm for threshold sensitivity
- - 40 dBm for dynamic range

### 5.5.3.3.3 Detection error magnitude

Depending on if the DUT is a tag or a reader, the test procedure will differ.

#### 5.5.3.3.3.1 The device under test is a tag

The DUT shall be additionally configured with the following configuration:

- Transmit a blink packet (as defined in 9.4.1 of ISO/IEC 24730-5) every 2 seconds. As a blink packet can include user defined data, the length is not fixed but should be kept below 64 bytes in total. The total packet length shall be specified by the manufacturer of the DUT.
- Each blink shall be followed by a receiving window of duration  $T_{RXON}$  equal to 1 second as defined in 9.2.5 of ISO/IEC 24730-5.

As a tag will transmit a blink packet before entering the receiving window, the testing application controlling the transmitting setup shall not start any transmission before the reception of the blink.

The transmission of packet by the transmitting setup shall start 3 milliseconds (ms) after the reception of the blink.

During the DUT's receiving window duration, the transmitting setup shall send 100 packets with an estimated interval of 2 ms between each packet. The transmitting setup shall stop to transmit packet 10 ms before the estimated end of the receiving window of the DUT.

The packet sent to the DUT shall be an AddRangingPeers command, as defined in 9.3.5 of ISO/IEC 24730-5, with the following parameter:

- Number of peers = 0

For the 2 RF input levels and the 3 channels (6 tests in total), the reception error shall be better than 95 % of all commands sent. Each test shall consist of a minimum of 2000 commands.

#### 5.5.3.3.3.2 The device under test is a reader

The transmitting setup shall transmit blink (as defined in 9.4.1 of ISO/IEC 24730-5) with an interval between blinks of 2 ms.

For the 2 RF input levels and the 3 channels (6 tests in total), the reception error shall be better than 95 % of all blinks sent. Each test shall consist of a minimum of 2000 blinks.

### 5.5.3.4 Test report

The test report shall contain a sketch of the test setup, the distance between the DUT and the measurement antenna, a list of the testing equipment used and all the measured data required to validate the parameters defined above.

If a test application is used, a brief narrative shall be included as an annex to the data.

The report shall also contain the uncertainties of the measurement equipment.

#### **5.5.4 DQPSK CSS modulation at 1 Mbits/s reception test**

##### **5.5.4.1 Test objective**

The objective of this test is to validate that the DUT provides the appropriate DQPSK CSS modulation waveform detection required for proper system performance.

##### **5.5.4.2 Test conditions**

The test setup shall be according to 5.5.1.

The DUT shall be configured with the following configuration:

- Occupied channel bandwidth: 22 MHz.
- Data bit rates: 1 Mbits/s.
- Modulation: DQPSK CSS.
- Transmit power shall be at a class 1 power between 0 dBm and +10 dBm EIRP.
- Media access: ALOHA (as defined in 8.5.4 of ISO/IEC 24730-5) which corresponds to CSMA/CA off (as defined in Table 27 in 9.3.2 of ISO/IEC 24730-5).

Additionally, as the operation of a tag and a reader differ, the configuration and test procedure will be different depending on if the DUT is a tag or a reader.

##### **5.5.4.3 Test measurements and requirements**

The person in charge of the test, or the test application, shall be able to validate the parameters described hereafter.

###### **5.5.4.3.1 Channel used**

The transmitting setup and the DUT shall be tested at the following channel, as defined in Table 2 in 7.3 and Table 6 in 7.4 of ISO/IEC 24730-5:

- Channel 2 : centre frequency of 2412 MHz
- Channel 8: centre frequency of 2442 MHz
- Channel 15: centre frequency of 2484 MHz

###### **5.5.4.3.2 Receiver input RF power levels**

The transmitting setup shall be configured to provide two input signals to the DUT:

- - 80 dBm for threshold sensitivity
- - 40 dBm for dynamic range

###### **5.5.4.3.3 Detection error magnitude**

Depending on if the DUT is a tag or a reader, the test procedure will differ.

#### 5.5.4.3.3.1 The device under test is a tag

The DUT shall be additionally configured with the following configuration:

- Transmit a blink packet (as defined in 9.4.1 of ISO/IEC 24730-5) every 2 seconds. As a blink packet can include user defined data, the length is not fixed but should be kept below 64 bytes in total. The total packet length shall be specified by the manufacturer of the DUT.
- Each blink shall be followed by a receiving window of duration  $T_{RXON}$  equal to 1 second as defined in 9.2.5 of ISO/IEC 24730-5.

As a tag will transmit a blink packet before entering the receiving window, the testing application controlling the transmitting setup shall not start any transmission before the reception of the blink.

The transmission of packet by the transmitting setup shall start 3 milliseconds (ms) after the reception of the blink.

During the DUT's receiving window duration, the transmitting setup shall send 200 packets with an estimated interval of 2 ms between each packet. The transmitting setup shall stop to transmit packet 10 ms before the estimated end of the receiving window of the DUT.

The packet sent to the DUT shall be an AddRangingPeers command, as defined in 9.3.5 of ISO/IEC 24730-5, with the following parameter:

- Number of peers = 0

For the 2 RF input levels and the 3 channels (6 tests in total), the reception error shall be better than 95 % of all commands sent. Each test shall consist of a minimum of 2000 commands.

#### 5.5.4.3.3.2 The device under test is a reader

The transmitting setup shall transmit blink (as defined in 9.4.1 of ISO/IEC 24730-5) with an interval between blinks of 2 ms.

For the 2 RF input levels and the 3 channels (6 tests in total), the reception error shall be better than 95 % of all blinks sent. Each test shall consist of a minimum of 2000 blinks.

#### 5.5.4.4 Test report

The test report shall contain a sketch of the test setup, the distance between the DUT and the measurement antenna, a list of the testing equipment used and all the measured data required to validate the parameters defined above.

If a test application is used, a brief narrative shall be included as an annex to the data.

The report shall also contain the uncertainties of the measurement equipment.

### 5.5.5 DQPSK CSS modulation at 250 Kbits/s reception test

#### 5.5.5.1 Test objective

The objective of this test is to validate that the DUT provides the appropriate DQPSK CSS modulation waveform detection required for proper system performance.

#### 5.5.5.2 Test conditions

The test setup shall be according to 5.5.1.

The DUT shall be configured with the following configuration:

- Occupied channel bandwidth: 22 MHz
- Data bit rates: 250 kbits/s
- Modulation: DQPSK CSS
- Transmit power shall be at a class 1 power between 0 dBm and +10 dBm EIRP
- Media access: ALOHA (as defined in 8.5.4 of ISO/IEC 24730-5) which correspond to CSMA/CA off (as defined in Table 27 in 9.3.2 of ISO/IEC 24730-5)

Additionally, as the operation of a tag and a reader differ, the configuration and test procedure will be different depending on if the DUT is a tag or a reader.

### 5.5.5.3 Test measurements and requirements

The person in charge of the test, or the test application, shall be able to validate the parameters described hereafter.

#### 5.5.5.3.1 Channel used

The transmitting setup and the DUT shall be tested at the following channel, as defined in Table 2 in 7.3 and Table 6 in 7.4 of ISO/IEC 24730-5:

- Channel 2 : centre frequency of 2412 MHz
- Channel 8: centre frequency of 2442 MHz
- Channel 15: centre frequency of 2484 MHz

#### 5.5.5.3.2 Receiver input RF power levels

The transmitting setup shall be configured to provide two input signals to the DUT:

- - 80 dBm for threshold sensitivity
- - 40 dBm for dynamic range

#### 5.5.5.3.3 Detection error magnitude

Depending on if the DUT is a tag or a reader, the test procedure will differ.

##### 5.5.5.3.3.1 The device under test is a tag

The DUT shall be additionally configured with the following configuration:

- Transmit a blink packet (as defined in 9.4.1 of ISO/IEC 24730-5) every 2 seconds. As a blink packet can include user defined data, the length is not fixed but should be kept below 64 bytes in total. The total packet length shall be specified by the manufacturer of the DUT.
- Each blink shall be followed by a receiving window of duration  $T_{RXON}$  equal to 1 second as defined in 9.2.5 of ISO/IEC 24730-5

As a tag will transmit a blink packet entering the receiving window, the testing application controlling the transmitting setup shall not start any transmission before the reception of the blink.



The transmission of packet by the transmitting setup shall start 3 milliseconds (ms) after the reception of the blink.

During the DUT's receiving window duration, the transmitting setup shall send 100 packets with an estimated interval of 2 ms between each packet. The transmitting setup shall stop to transmit packet 10 ms before the estimated end of the receiving window of the DUT.

The packet sent to the DUT shall be an AddRangingPeers command, as defined in 9.3.5 of ISO/IEC 24730-5, with the following parameter:

— Number of peers = 0

For the 2 RF input levels and the 3 channels (6 tests in total), the reception error shall be better than 95 % of all commands sent. Each test shall consist of a minimum of 2000 commands.

#### **5.5.5.3.3.2 The device under test is a reader**

The transmitting setup shall transmit blink (as defined in 9.4.1 of ISO/IEC 24730-5) with an interval between blinks of 2 ms.

For the 2 RF input levels and the 3 channels (6 tests in total), the reception error shall be better than 95 % of all blinks sent. Each test shall consist of a minimum of 2000 blinks.

#### **5.5.5.4 Test report**

The test report shall contain a sketch of the test setup, the distance between the DUT and the measurement antenna, a list of the testing equipment used and all the measured data required to validate the parameters defined above.

If a test application is used, a brief narrative shall be included as an annex to the data.

The report shall also contain the uncertainties of the measurement equipment.

### **5.6 Application layer conformance tests**

The following tests shall be performed and validated sequentially (5.6.1 before 5.6.2, 5.6.2 before 5.6.3, etc...).

#### **5.6.1 Test setup**

The measurement equipment shall consist of an anechoic chamber, a transmitting setup and a receiving setup.

The DUT shall be a RTLS tag or reader.

The DUT shall be placed at a distance between 1 meter and 3 meters from the measurement antenna.

The data will be transmitted by a transmitting setup. The person in charge of the test shall verify that the transmitting setup complies with the RF transmission test, 5.4 of this part of ISO/IEC 24769.

The transmitting setup shall be configured in order that the DUT RF input signal is -40 dBm.

Figure 4, in 5.5.1, shows the required test setup.

## 5.6.2 Set and get configuration vector command

### 5.6.2.1 Test objective

The objective of this test is to validate that the DUT is able to change or report its configuration as defined in the ISO/IEC 24730-5 in order to insure proper system operation.

### 5.6.2.2 Test conditions

The test setup shall be according to 5.6.15.6.2.

The DUT shall be configured with the following configuration:

- Occupied channel bandwidth: 80 MHz.
- Data bit rates: 1 Mbits/s.
- Modulation: 2-ary orthogonal CSS.
- Transmit power shall be at a class 1 power between 0 dBm and +10 dBm EIRP.
- Media access: ALOHA (as defined in 8.5.4 of ISO/IEC 24730-5) which correspond to CSMA/CA off (as defined in Table 27 in 9.3.2 of ISO/IEC 24730-5).
- Transmit a blink packet (as defined in 9.4.1 of ISO/IEC 24730-5) every 1 second. As a blink packet can include user defined data, the length is not fixed but should be kept below 64 bytes in total. The total packet length shall be specified by the manufacturer of the DUT.
- Each blink shall be followed by a receiving window of duration  $T_{RXON}$  equal to 5 milliseconds as defined in 9.2.5 of ISO/IEC 24730-5.

### 5.6.2.3 Test measurement and requirements

The person in charge of the test, or the test application, shall be able to validate the parameters described hereafter.

#### 5.6.2.3.1 GetConfigVector command

After reception of a blink from the DUT, the transmitting setup shall send a GetConfigVector command as defined in 9.3.3 of ISO/IEC 24730-5.

The DUT shall reply with GetConfigVector report as described in 9.4.4 of ISO/IEC 24730-5. The configuration vector shall correspond to the default configuration defined in 9.7 of ISO/IEC 24730-5.

#### 5.6.2.3.2 SetConfigVector command

After reception of a blink from the DUT, the transmitting setup shall send a SetConfigVector command as defined in 9.3.2 of ISO/IEC 24730-5.

The configuration vector shall be identical to the default configuration except for the data rate which shall be modified to 250 Kbits/s.

The person in charge of the test, or the test application, shall validate that the DUT correctly changed its data rate.

The person in charge of the test, or the test application, could validate the complete configuration vector by sending a GetConfigVector and comparing the vector received with the one set.

#### 5.6.2.4 Test report

The test report shall contain a sketch of the test setup, the distance between the DUT and the measurement antenna, a list of the testing equipment used and all the measured data required to validate the parameters defined above.

If a test application is used, a brief narrative shall be included as an annex to the data.

The report shall also contain the uncertainties of the measurement equipment.

#### 5.6.3 Set, add and get ranging peer

##### 5.6.3.1 Test objective

The objective of this test is to validate that the DUT understands and handle the command as defined in the ISO/IEC 24730-5 in order to insure proper system operation.

##### 5.6.3.2 Test conditions

The test setup shall be according to 5.6.1.

The DUT shall be configured with the following configuration:

- Occupied channel bandwidth: 80 MHz.
- Data bit rates: 1 Mbits/s.
- Modulation: 2-ary orthogonal CSS.
- Transmit power shall be at a class 1 power between 0 dBm and +10 dBm EIRP.
- Media access: ALOHA (as defined in 8.5.4 of ISO/IEC 24730-5) which correspond to CSMA/CA off (as defined in Table 27 in 9.3.2 of ISO/IEC 24730-5).
- Transmit a blink packet (as defined in 9.4.1 of ISO/IEC 24730-5) every 1 second. As a blink packet can include user defined data, the length is not fixed but should be kept below 64 bytes in total. The total packet length shall be specified by the manufacturer of the DUT.
- Each blink shall be followed by a receiving window of duration  $T_{RXON}$  equal to 5 milliseconds as defined in 9.2.5 of ISO/IEC 24730-5.

##### 5.6.3.3 Test measurement and requirements

The person in charge of the test, or the test application, shall be able to validate the parameters described hereafter.

After reception of a blink from the DUT, the transmitting setup shall send three consecutive commands in the same packet. As defined in 9.4.2 of ISO/IEC 24730-5, the DUT shall handle all three commands. The commands shall be sent in the same order as they are defined.

The first command shall be a SetRangingPeers command with the following parameters as defined in 9.3.4 of the ISO/IEC 24730-5:

- Number of peers: 1
- MAC address of peer 1: 0x01 0x02 0x03 0x04 0x05 0x06 (hexadecimal values)

- Ranging packet exchange type for peer 1: 0
- Application ID of peer 1: 1

The second command shall be an AddRangingPeers command with the following parameters as defined in 9.3.5 of the ISO/IEC 24730-5:

- Number of peers: 1
- MAC address of peer 1: 0x07 0x08 0x09 0x0A 0x0B 0x0C (hexadecimal values)
- Ranging packet exchange type for peer 1: 0
- Application ID of peer 1: 2

The third command shall be a GetRangingPeers command as defined in 9.3.6 of ISO/IEC 24730-5.

At the end of its receiving window, the DUT shall reply with a GetRangingPeers report as defined in 9.4.5 of ISO/IEC 24730-5.

Information about the peers shall be identical but the order does not have any influence. The peer 1 can be the one added by the AddRangingPeers command.

### 5.6.3.4 Test report

The test report shall contain a sketch of the test setup, the distance between the DUT and the measurement antenna, a list of the testing equipment used and all the measured data required to validate the parameters defined above.

If a test application is used, a brief narrative shall be included as an annex to the data.

The report shall also contain the uncertainties of the measurement equipment.

### 5.6.4 Switch state command test

#### 5.6.4.1 Test objective

The objective of this test is to validate that the DUT understands and handle the command as defined in the ISO/IEC 24730-5 in order to insure proper system operation.

#### 5.6.4.2 Test conditions

The test setup shall be according to 5.6.1.

The DUT shall be configured with the following configuration:

- Occupied channel bandwidth: 80 MHz.
- Data bit rates: 250 kbits/s.
- Modulation: 2-ary orthogonal CSS.
- Transmit power shall be at a class 1 power between 0 dBm and +10 dBm EIRP.
- Media access: ALOHA (as defined in 8.5.4 of ISO/IEC 24730-5) which correspond to CSMA/CA off (as defined in Table 27 in 9.3.2 of ISO/IEC 24730-5).

- Transmit a blink packet (as defined in 9.4.1 of ISO/IEC 24730-5) every 1 second. As a blink packet can include user defined data, the length is not fixed but should be kept below 64 bytes in total. The total packet length shall be specified by the manufacturer of the DUT.
- Each blink shall be followed by a receiving window of duration  $T_{RXON}$  equal to 5 milliseconds as defined in 9.2.5 of ISO/IEC 24730-5.

The data rate is valid only until the switch state to default state test has been performed. After this test, the DUT shall use the default 1 Mbits/s data rate.

#### 5.6.4.3 Test measurement and requirements

The person in charge of the test, or the test application, shall be able to validate the parameters described hereafter.

##### 5.6.4.3.1 Switch to default state

As defined in the Table 42 in 9.7 of ISO/IEC, the DUT shall change its configuration to communicate with a data rate of 1 Mbits/s upon reception of a switch to default state command.

After reception of a blink from the DUT, the transmitting setup shall send a switch to default state command with a data rate of 250 Kbits/s.

To validate the state change of the DUT, the person in charge of the test or the test application shall verify that the DUT does not transmit any blink at the data rate 250 Kbits/s for 10 times the duration of the blink interval. Then, the person in charge of the test or the test application shall verify that the DUT does transmit blink at the data rate of 1 Mbits/s.

For the rest of the tests concerning the Switch state command, the DUT shall keep the default configuration defined in Table 42 in 9.7 of ISO/IEC 24730-5.

##### 5.6.4.3.2 Switch to wait state

After reception of a blink from the DUT, the transmitting setup shall send a switch to wait state command with a WaitMaxDuration equal to 5 seconds as defined in 9.3.1.5 of ISO/IEC 24730-5.

To validate the state change of the DUT, the person in charge of the test or the test application shall verify that the DUT does not transmit any blink during 5 seconds. Then, the person in charge of the test or the test application shall also verify that the DUT does transmit blink after the waiting duration is over.

##### 5.6.4.3.3 Switch to sleep state

After reception of a blink from the DUT, the transmitting setup shall send a switch to sleep state command with sleep duration equal to 5 seconds as defined in 9.3.1.7 of ISO/IEC 24730-5.

To validate the state change of the DUT, the person in charge of the test or the test application shall verify that the DUT does not transmit any blink during 5 seconds. Then, the person in charge of the test or the test application shall also verify that the DUT does transmit blink after the sleeping duration is over.

##### 5.6.4.3.4 Switch to blink state

After reception of a blink from the DUT, the transmitting setup shall send a switch to blink state command with the following parameters as defined in 9.3.1.4 of ISO/IEC 24730-5:

- $T_{blink}$  : 2 seconds
- $M_{blink}$  : 2
- $T_{rxon}$  : 5 ms

To validate the state change of the DUT, the person in charge of the test or the test application shall verify that the DUT blink's interval changed according to the  $T_{\text{blink}}$  parameter.

The person in charge of the test or the test application shall also verify that the DUT does not have a receiving window after each blink by sending a switch state to default state command to the DUT and monitoring the interval between two blinks.

Finally, the DUT shall be in the default configuration at the end of this test.

### 5.6.4.3.5 Switch to Range state

In order to perform this test, the test described in 5.6.3 shall have been validated.

After reception of a blink from the DUT, the transmitting setup shall send two consecutive commands in the same packet. As defined in 9.4.2 of ISO/IEC 24730-5, the DUT shall handle both commands. The commands shall be sent in the same order as they are defined

The first command shall be a SetRangingPeers command with the following parameters as defined in 9.3.4 of the ISO/IEC 24730-5:

- Number of peers: 1
- MAC address of peer 1: MAC address of the transmitting setup
- Ranging packet exchange type for peer 1: 0
- Application ID of peer 1: Application ID of the transmitting setup

The second command shall be a switch to range state command with the following parameters as defined in 9.3.1.6 of ISO/IEC 24730-5:

- Report to initiator: 0 (no report)
- Intermediate sleep duration : 0 ms
- Max repetition number : 1

To validate the change of state of the DUT, the person in charge of the test or the test application shall verify that the DUT sends a T1R1 packet as specified in 9.4.7.4.1 of ISO/IEC 24730-5.

### 5.6.4.4 Test report

The test report shall contain a sketch of the test setup, the distance between the DUT and the measurement antenna, a list of the testing equipment used and all the measured data required to validate the parameters defined above.

If a test application is used, a brief narrative shall be included as an annex to the data.

The report shall also contain the uncertainties of the measurement equipment.

## 5.6.5 Ranging packet exchange

### 5.6.5.1 Test objective

The objective of this test is to validate that the DUT is able to perform the ranging packet exchange as defined in the ISO/IEC 24730-5 in order to insure proper system operation.

### 5.6.5.2 Test conditions

The test setup shall be according to 5.6.1.

The DUT shall be configured with the following configuration:

- Occupied channel bandwidth: 80 MHz.
- Data bit rates: 1 Mbits/s.
- Modulation: 2-ary orthogonal CSS.
- Transmit power shall be at a class 1 power between 0 dBm and +10 dBm EIRP.
- Media access: ALOHA (as defined in 8.5.4 of ISO/IEC 24730-5) which correspond to CSMA/CA off (as defined in Table 27 in 9.3.2 of ISO/IEC 24730-5).
- Transmit a blink packet (as defined in 9.4.1 of ISO/IEC 24730-5) every 1 second. As a blink packet can include user defined data, the length is not fixed but should be kept below 64 bytes in total. The total packet length shall be specified by the manufacturer of the DUT.
- Each blink shall be followed by a receiving window of duration  $T_{RXON}$  equal to 5 milliseconds as defined in 9.2.5 of ISO/IEC 24730-5.

In order to perform this test, the test described in 5.6.4.3.5 shall have been validated.

### 5.6.5.3 Test measurement and requirements

The person in charge of the test, or the test application, shall be able to validate the parameters described hereafter.

#### 5.6.5.3.1 Ranging packet exchange type 1

After reception of a blink from the DUT, the transmitting setup shall send two consecutive commands in the same packet. As defined in 9.4.2 of ISO/IEC 24730-5, the DUT shall handle both commands. The commands shall be sent in the same order as they are defined

The first command shall be a SetRangingPeers command with the following parameters as defined in 9.3.4 of the ISO/IEC 24730-5:

- Number of peers: 1
- MAC address of peer 1: MAC address of the transmitting setup
- Ranging packet exchange type for peer 1: 0
- Application ID of peer 1: Application ID of the transmitting setup

The second command shall be a switch to range state command with the following parameters as defined in 9.3.1.6 of ISO/IEC 24730-5:

- Report to initiator: 0 (no report)
- Intermediate sleep duration : 0 ms
- Max repetition number : 1

The person in charge of the test or the test application shall verify that the DUT performs a ranging packet exchange type 1 as defined in 9.5.1 of ISO/IEC 24730-5.

### 5.6.5.3.2 Ranging packet exchange type 2

After reception of a blink from the DUT, the transmitting setup shall send two consecutive commands in the same packet. As defined in 9.4.2 of ISO/IEC 24730-5, the DUT shall handle both commands. The commands shall be sent in the same order as they are defined

The first command shall be a SetRangingPeers command with the following parameters as defined in 9.3.4 of the ISO/IEC 24730-5:

- Number of peers: 1
- MAC address of peer 1: MAC address of the transmitting setup
- Ranging packet exchange type for peer 1: 1
- Application ID of peer 1: Application ID of the transmitting setup

The second command shall be a switch to range state command with the following parameters as defined in 9.3.1.6 of ISO/IEC 24730-5:

- Report to initiator: 0 (no report)
- Intermediate sleep duration : 0 ms
- Max repetition number : 1

The person in charge of the test or the test application shall verify that the DUT performs a ranging packet exchange type 2 as defined in 9.5.2 of ISO/IEC 24730-5.

### 5.6.5.3.3 Ranging packet exchange type 3

After reception of a blink from the DUT, the transmitting setup shall send two consecutive commands in the same packet. As defined in 9.4.2 of ISO/IEC 24730-5, the DUT shall handle both commands. The commands shall be sent in the same order as they are defined

The first command shall be a SetRangingPeers command with the following parameters as defined in 9.3.4 of the ISO/IEC 24730-5:

- Number of peers: 1
- MAC address of peer 1: MAC address of the transmitting setup
- Ranging packet exchange type for peer 1: 2
- Application ID of peer 1: Application ID of the transmitting setup

The second command shall be a switch to range state command with the following parameters as defined in 9.3.1.6 of ISO/IEC 24730-5:

- Report to initiator: 0 (no report)
- Intermediate sleep duration : 0 ms
- Max repetition number : 1

The person in charge of the test or the test application shall verify that the DUT performs a ranging packet exchange type 3 as defined in 9.5.3 of ISO/IEC 24730-5.



#### 5.6.5.3.4 Ranging packet exchange type 4

After reception of a blink from the DUT, the transmitting setup shall send two consecutive commands in the same packet. As defined in 9.4.2 of ISO/IEC 24730-5, the DUT shall handle both commands. The commands shall be sent in the same order as they are defined

The first command shall be a SetRangingPeers command with the following parameters as defined in 9.3.4 of the ISO/IEC 24730-5:

- Number of peers: 1
- MAC address of peer 1: MAC address of the transmitting setup
- Ranging packet exchange type for peer 1: 3
- Application ID of peer 1: Application ID of the transmitting setup

The second command shall be a switch to range state command with the following parameters as defined in 9.3.1.6 of ISO/IEC 24730-5:

- Report to initiator: 0 (no report)
- Intermediate sleep duration : 0 ms
- Max repetition number : 1

The person in charge of the test or the test application shall verify that the DUT performs a ranging packet exchange type 4 as defined in 9.5.4 of ISO/IEC 24730-5.

#### 5.6.5.4 Test report

The test report shall contain a sketch of the test setup, the distance between the DUT and the measurement antenna, a list of the testing equipment used and all the measured data required to validate the parameters defined above.

If a test application is used, a brief narrative shall be included as an annex to the data.

The report shall also contain the uncertainties of the measurement equipment.

### 5.6.6 Ranging report

#### 5.6.6.1 Test objective

The objective of this test is to validate that the DUT is able to report a measurement after performing a ranging packet exchange as defined in the ISO/IEC 24730-5 in order to insure proper system operation.

#### 5.6.6.2 Test conditions

The test setup shall be according to 5.6.1.

The DUT shall be configured with the following configuration:

- Occupied channel bandwidth: 80 MHz.
- Data bit rates: 1 Mbits/s.
- Modulation: 2-ary orthogonal CSS.

- Transmit power shall be at a class 1 power between 0 dBm and +10 dBm EIRP.
- Media access: ALOHA (as defined in 8.5.4 of ISO/IEC 24730-5) which correspond to CSMA/CA off (as defined in Table 27 in 9.3.2 of ISO/IEC 24730-5).
- Transmit a blink packet (as defined in 9.4.1 of ISO/IEC 24730-5) every 1 second. As a blink packet can include user defined data, the length is not fixed but should be kept below 64 bytes in total. The total packet length shall be specified by the manufacturer of the DUT.
- Each blink shall be followed by a receiving window of duration  $T_{RXON}$  equal to 5 milliseconds as defined in 9.2.5 of ISO/IEC 24730-5.

### 5.6.6.3 Test measurement and requirements

In order to perform this test, the test described in 5.6.4.3.5 shall have been validated.

After reception of a blink from the DUT, the transmitting setup shall send two consecutive commands in the same packet. As defined in 9.4.2 of ISO/IEC 24730-5, the DUT shall handle both commands. The commands shall be sent in the same order as they are defined

The first command shall be a SetRangingPeers command with the following parameters as defined in 9.3.4 of the ISO/IEC 24730-5:

- Number of peers: 1
- MAC address of peer 1: MAC address of the transmitting setup
- Ranging packet exchange type for peer 1: 0
- Application ID of peer 1: Application ID of the transmitting setup

The second command shall be a switch to range state command with the following parameters as defined in 9.3.1.6 of ISO/IEC 24730-5:

- Report to initiator: 2 (broadcast report)
- Intermediate sleep duration : 0 ms
- Max repetition number : 1

The person in charge of the test or the test application shall verify that the DUT performs a ranging packet exchange type 1 as defined in 9.5.1 of ISO/IEC 24730-5 and then, broadcast a ranging report as defined in 9.4.6 of ISO/IEC 24730-5.

### 5.6.6.4 Test report

The test report shall contain a sketch of the test setup, the distance between the DUT and the measurement antenna, a list of the testing equipment used and all the measured data required to validate the parameters defined above.

If a test application is used, a brief narrative shall be included as an annex to the data.

The report shall also contain the uncertainties of the measurement equipment.

## **Annex A** (normative)

### **Technical requirements of the testing equipment**

#### **A.1 Arbitrary waveform generator**

The arbitrary waveform generator, or its equivalent, shall have a frequency range up to 500 MHz minimum. The Tektronix AWG2041 Arbitrary waveform generator with a frequency range up to 500 MHz is sufficient for this test. Any unit that matches performance characteristics of the AWG2041 is also acceptable.

#### **A.2 Signal generator**

The signal generator, or its equivalent, shall have a baseband generator of at least 80 MHz. The Agilent ESG E4438C-602 vector signal generator with 80 MHz RF modulation bandwidth is sufficient for this test. Any unit that matches performance characteristics of the E4438C-602 is also acceptable.

#### **A.3 Oscilloscope**

The oscilloscope shall have a bandwidth of at least 1 GHz. The Tektronix DPO 7104 with 1 GHz bandwidth and 10 GS/s is sufficient for this test. Any unit that matches performance characteristics of the DPO 7104 is also acceptable.

#### **A.4 Spectrum analyzer**

The spectrum analyzer, or its equivalent, shall have an analysis bandwidth of at least 80 MHz. The Agilent E4443A spectrum analyzer with 80 MHz bandwidth option is sufficient for this test. Any unit that matches performance characteristics of the E4438C-602 is also acceptable.

#### **A.5 Antenna**

The measurement antenna shall be a 2.4 GHz dipole antenna. Unless otherwise stated in the test procedure, the measurement antenna shall be placed between 1 and 3 meters from the DUT.

#### **A.6 Frequency mixer**

The frequency mixer shall have an input frequency between DC and 1 GHz, and an output frequency upper limit bigger than 3 GHz. The Mini circuits ZEM-4300+ with an input frequency between DC and 1 GHz, and an output frequency up to 4.3 GHz is sufficient for this test. Any unit that matches performance characteristics of the ZEM-4300+ is also acceptable.

## Bibliography

- [1] ISO/IEC 24730-1: *Information technology — Automatic identification and data capture techniques — Real Time Locating Systems (RTLS) — Part 1: Application program interface (API)*
- [2] ISO/IEC 24730-2: *Information technology — Automatic identification and data capture techniques — Real Time Locating Systems (RTLS) — Part 2: 2.4 GHz air interface protocol*
- [3] ISO/IEC TR 24769-2: *Information technology — Automatic identification and data capture techniques — RTLS device conformance test methods — Test methods for air interface communication at 2.4 GHz*



